

FEATURES AND SPECIFICATIONS

Material meets the requirements for non-combustibility in accordance with ASTM E-136

- High definition, crisp details
- Adjustable height
- Fast, easy installation
- Glass fibre reinforced gypsum cement
- White unprimed finish
- Ready to prime and paint
- Supplied in 3 pieces

- Net weights:
 - Complete mantel: 180 lbs
 - Mantel top: 120 lbs
 - Each mantel leg: 30 lbs
- Boxed weight: 205 lbs
- 3/4" wide X 1" deep rabbet to accommodate a marble, stone or other noncombustible filler panel material insert (not supplied with mantel)

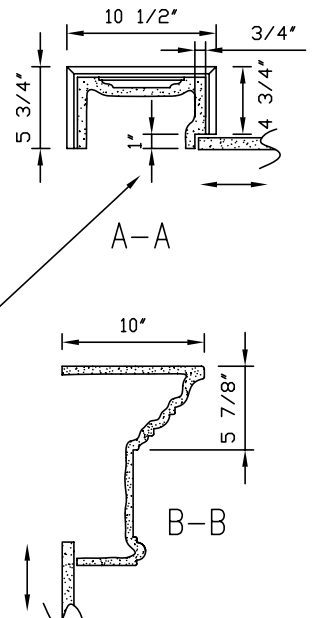

All dimensions & weights are approximate

DO NOT SCALE

Tel: 1-800-665-3454

Copyright (c) 2005 Architectural Moldings Ltd.
Information contained in this drawing shall not be copied or used without the express permission of Architectural Moldings Ltd.

Fax: 1-800-461-4445

Date: Feb. 1, 2005

<http://www.balmer.com/facts/4112.pdf>