

FEATURES AND SPECIFICATIONS

Material meets the requirements for non-combustibility in accordance with ASTM E-136

- High definition, crisp details
- Adjustable height
- Fast, easy installation
- Glass fibre reinforced gypsum cement
- White unprimed finish
- Ready to prime and paint
- Supplied in 3 pieces

- Net weights:

Complete mantel: 180 lbs

Mantel top: 120 lbs

Each mantel leg: 30 lbs

- Boxed weight: 205 lbs

- 3/4" wide X 1" deep rabbet to accommodate a marble, stone or other noncombustible filler panel material insert (not supplied with mantel)

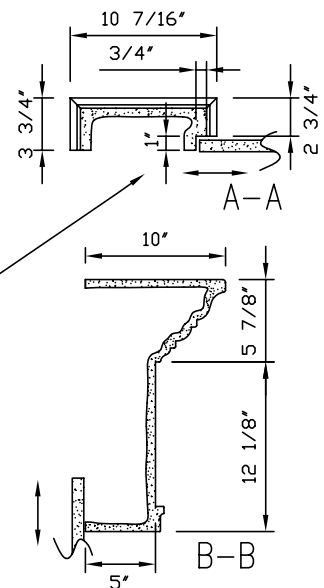

All dimensions & weights are approximate

DO NOT SCALE

Copyright (c) 2005 Architectural Mouldings Ltd.
 Information contained in this drawing shall not be copied or used without the express permission of Architectural Mouldings Ltd.

Date: Feb. 1, 2005