

FEATURES AND SPECIFICATIONS

Material meets the requirements for non-combustibility in accordance with ASTM E-136

- High definition, crisp details
- Adjustable height
- Fast, easy installation
- Material is sealed from the factory and requires no further finishing
- Supplied in 3 pieces
- Net weights:

Complete mantel:	150 lbs
Mantel top:	100 lbs
Each mantel leg:	25 lbs
- Crated weight:	180 lbs

All dimensions & weights are approximate

DO NOT SCALE

Marble, stone, or other noncombustible filler panel material (not supplied with mantel) combined with adhesive must accommodate 1" cavity at mantel legs to support the bearing surface of the inside edges of the mantel shelf and legs against the wall on the firebox side, and to cover the wall area between the firebox opening and mantel components. At least 1" of the surround filler panel should extend behind the inside edges of the mantel for support.

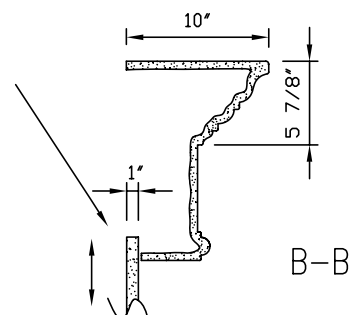
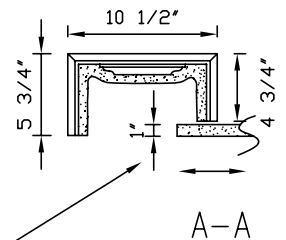

Copyright (c) 2004 Architectural Moldings Ltd.
Information contained in this drawing shall not be copied or used without the express permission of Architectural Moldings Ltd.

Date: Jan. 5, 2007