

Bourges 1911 Noncombustible Fireplace Mantel Fact Sheet

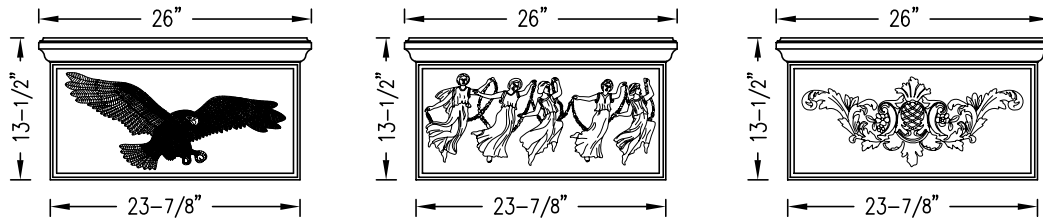
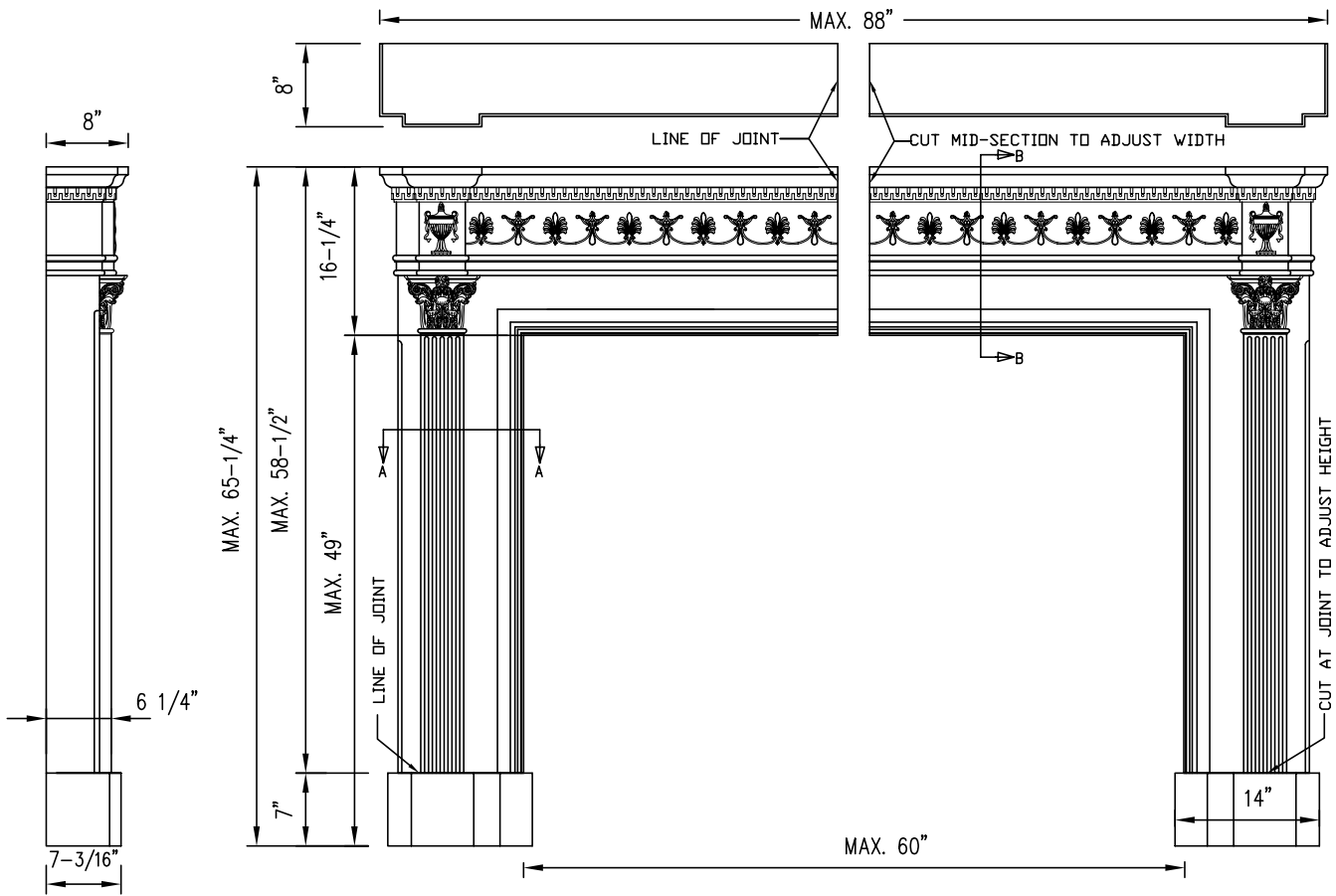

Select one of the three center panels shown to mount over the seam between the left and right halves

FEATURES AND SPECIFICATIONS

Material meets the requirements for non-combustibility in accordance with ASTM E-136

- High definition, crisp details
- Adjustable height and width
- Fast, easy installation
- Glass fibre reinforced gypsum cement
- White unprimed finish
- Ready to prime and paint
- Supplied in 5 pieces

- Net weights:
 - Complete mantel: 179 lbs
 - Each foot: 12 lbs
 - Each half: 70 lbs
 - Center panel: 15 lbs
- Crated qty per unit: 1
- Crated weight: 240 lbs
- 3/8" wide X 7/8" deep rabbet to accommodate a marble, stone or other noncombustible filler panel material insert (not supplied with mantel)

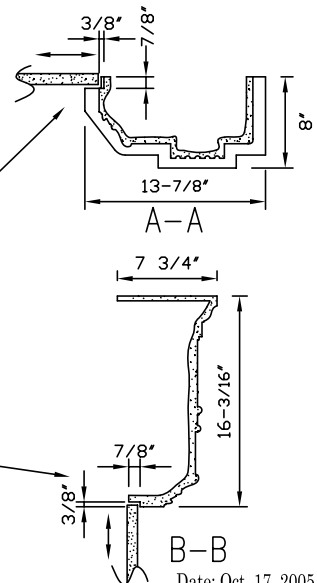

All dimensions & weights are approximate

DO NOT SCALE

Copyright (c) 2004 Architectural Mouldings Ltd.
Information contained in this drawing shall not be copied or used without the express permission of Architectural Mouldings Ltd.

Date: Oct. 17, 2005